

FE3R08-12N

Three-wheels Rear Drive Forklift

 **Ready for Lithium power**

ADVANTAGES

- Smart & Compact Design with Great Mobility
- Maintenance-free AC Drive System
- Intelligent Computer Controller System
- On-board Self-Diagnostic Display
- Excellent Safety and Reliability
- Easy Service & Maintenance
- Standard Side Battery Extraction
- Great Comfort and Ergonomic Design
- Easy EPS Steering (for FE3R08-12N)

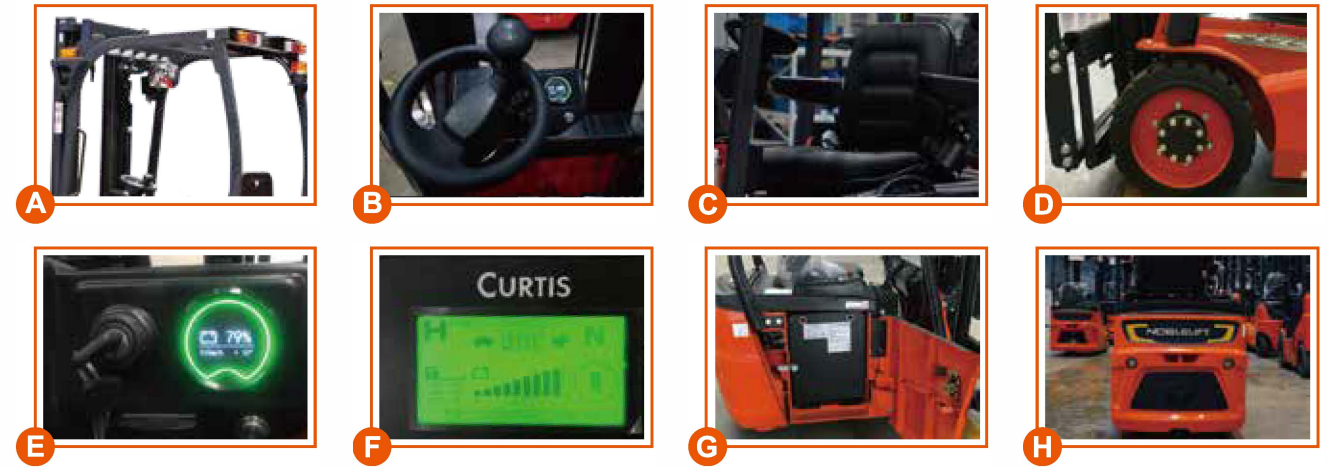

A Front LED Lights, Steering lights, Rear Combination Lights, Warning light standard, safe to work in dark environment such as containers or in the night.

B-C Small Diameter Steering Wheel with Spinner Knob, Adjustable Steering wheel position and seat to optimize the comfortness of the operator for long time operation.

D Small Diameter Solid Front Wheels for easy and smooth motion.

E-F Intelligent ZAPI or Curtis Self-diagnostic display for easy operation and maintenance, Standard Rear Wheel Position Sensor & Display with Speed Reduction at Turning.

G Optional different battery capacities for different operation needs, optional Aquamatic battery self-filling system for easy battery maintenance.

H Extremely compact design with small width and turning radius for easy operation in confined spaces.



Variable wheelbase design:
Mast tilting function realised through the movement of front axle.



Battery compartment with rollers for 08-12N.

Fully openable covers for easy service and maintenance
Standard Side Battery Extraction for easy battery replacement.



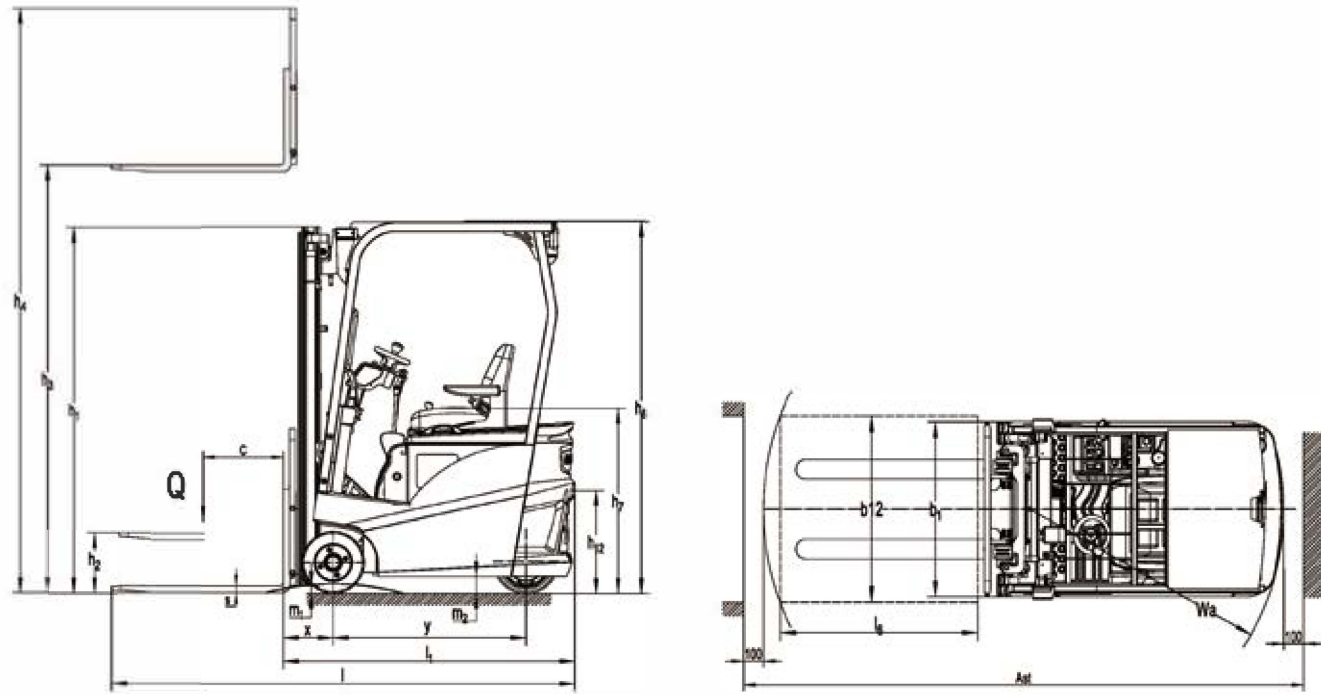

Mast Table FE3R08-12N								
Designation	Lift height	Free Lift	Closed mast height	Extended mast height	Tilt forward/backward $\alpha / \beta(^{\circ})$	Capacity table (kg) C=500mm without sideshift, single solid tyres		
	h3 (mm)	h2 (mm)	h1 (mm)	h4 (mm)		FE3R08N	FE3R10N	FE3R12N
Two-stage ZT	2500	95	1715	3365	3/5	800	1000	1200
	2700	95	1815	3565	3/5	800	1000	1200
	3000	95	1965	3865	3/5	800	1000	1200
	3300	95	2155	4165	3/5	750	1000	1200
	3500	95	2215	4365	3/5	720	920	1050
	3700	95	2315	4565	3/5	700	850	950
Two-stage ZZ	4000	95	2515	4865	3/5	650	800	900
	2500	875	1715	3365	3/5	800	1000	1200
	2700	975	1815	3565	3/5	800	1000	1200
	3000	1125	1965	3865	3/5	800	1000	1200
	3300	1275	2155	4165	3/5	750	1000	1200
	3500	1375	2215	4365	3/5	720	920	1050
Three-stage DZ	3700	1475	2315	4565	3/5	700	800	950
	4000	1625	2515	4865	3/5	650	750	900
	4000	1061	1900	3565	3/5	/	750	900
	4350	1161	2000	3790	3/3	/	650	800
	4500	1211	2050	3890	3/3	/	550	700
	4800	1311	2150	4090	3/3	/	450	550
	5000	1411	2250	4240	3/3	/	400	450

Free height (no load-backrest) +305

Type sheet for industrial truck acc. to VDI 2198

1KG=2.2LB 1INCH=25.4MM

Identification					
1.2	Manufacturer's type designation		FE3R08N	FE3R10N	FE3R12N
1.3	Drive: electric (battery or mains), diesel, petrol gas, manual)		electric	electric	electric
1.4	Type of operation (hand, pedestrian, standing, seated, order-picker)		seated	seated	seated
1.5	Load capacity/rated load	Q(kg)	800	1000	1200
1.6	Load centre distance	c(mm)	500	500	500
1.8	Load distance, centre of drive axle to fork	x(mm)	265	265	265
1.9	wheelbase	y(mm)	841/923	951/1033	991/1073
Weights					
2.1	Service weight incl. battery	kg	1800	1910	2080
2.2	Axle loading, laden front/rear	kg	2300/300	2600/310	2950/330
2.3	Axle loading, unladen front/rear	kg	770/1020	850/1060	880/1220
Wheels, Chassis					
3.1	Type: solid rubber, superelastic, pneumatic, polyurethane		solid rubber/polyurethane	solid rubber/polyurethane	solid rubber/polyurethane
3.2	Tyres size, front		13x4 1/2x8	13x4 1/2x8	13x4 1/2x8
3.3	Tyres size, rear		Φ250x82	Φ250x82	Φ250x82
3.5	Wheels, number front/rear (x=driven wheels)		2/1x	2/1x	2/1x
3.6	Track width, front	b10(mm)	765	765	765
3.7	Track width, rear	b11(mm)	0	0	0
Basic Dimensions					
4.1	Mast/fork carriage tilt forward/backward	$\alpha/\beta(^{\circ})$	3/5	3/5	3/5
4.2	lowered mast height	h1(mm)	1965	1965	1965
4.3	Free lift	h2(mm)	95	95	95
4.4	Lift height	h3(mm)	3000	3000	3000
4.5	Extended mast height	h4(mm)	3865	3865	3865
4.7	Overhead load guard height	h6(mm)	1975	1975	1975
4.8	Seat height/standing height	h7(mm)	980	980	980
4.12	Coupling height	h10(mm)	540	540	540
4.19	Overall length	l1(mm)	2290	2400	2460
4.20	Length to face of forks	l2(mm)	1370	1480	1545
4.21	Overall width	b1(mm)	880	880	880
4.22	Fork dimensions	s/e l (mm)	35/100/920	35/100/920	40/120/920
4.24	Fork carriage width	b3(mm)	825	825	825
4.31	Ground clearance, laden, under mast	m1(mm)	80	80	80
4.32	Ground clearance, centre of wheelbase	m2(mm)	90	90	90
4.33	Aisle width for pallets 1000x1200 crossways	Ast(mm)	2716	2921	2951
4.34	Aisle width for pallets 800x1200 lengthways	Ast(mm)	2879	3039	3069
4.35	Turning radius	Wa(mm)	1160	1320	1350
Performance Data					
5.1	Travel speed, laden/unladen	km/h	8/9	7.5/9	7/9
5.2	Lift speed, laden/unladen	m/s	0.17/0.28	0.16/0.22	0.15/0.22
5.3	lowering speed, laden/unladen	m/s	0.23/0.22	0.16/0.20	0.17/0.20
5.5	Drawbar pull, laden/unladen S2 60 min	N	1500/1700	1500/1700	1800/2300
5.7	Max. Gradient performance, laden/unladen S2 5 min	%	6/10	6/10	6/10
5.10	Service brake		hydraulic	hydraulic	hydraulic
E-Motor					
6.1	Drive motor rating S2 60 min	kW	2.5	2.5	2.5
6.2	Lift motor rating at S3 15%	kW	3	3	3
6.3	Battery standard		DIN	DIN	DIN
6.4	Battery voltage, nominal capacity K5	V/Ah	24/280 (360/400)(Optional)	24/420(480/540)(Optional)	24/420(480/540)(Optional)
	Battery weight	kg	280/364/428	392/440/488	392/440/488
6.4	Battery dimensions l/w/h	mm	806/263/628	806/372/628	806/372/628
Other Details					
8.1	Type of drive control		AC	AC	AC
8.2	Operating pressure for attachments	Mpa	11.5	13.5	15.5
8.3	Oil volume for attachments	l/min	11	11	11
8.4	Sound level at driver's ear according to EN 12 053	dB(A)	70	70	70