

FE3D16-20N

3-wheel Double Drive Electric Forklift

 **Optional cold storage special configuration**

 **Ready for Lithium power**

ADVANTAGES

- 48 Volt Electrical TOTAL AC System
- All-Around Dual Front Wheel Drive
- Curtis Intelligent Computer Control System
- Great comfort and ergonomic design
- Excellent Safety and Reliability
- Easy Service & Maintenance
- Smart Open Side Battery Access Door
- With On-Board Curtis Self-Diagnostics (IMS) Display



AC 48 Volt Electrical TOTAL AC System with Low maintenance Costs

The Total AC system design utilizes two AC drive motors and one AC hydraulic motor to achieve high performance with minimal costs. AC motors eliminate the need for motor brush or contactor checks or replacements, thereby greatly reducing overall routine maintenance costs.

AC motors also provide high operating efficiency, long operating life, and longer run times than conventional DC type motors. The truck's power saving function enhances the truck's ability to operate for longer periods without reducing productivity or performance.

All-Around Dual Front Wheel Drive

All-around Dual AC front wheel drive motors for the N series provide powerful travel and excellent turning performance even in the most undesirable floor conditions. Stability of the truck is further enhanced through a low mounted battery keeping the truck center of gravity lower to the ground.



Curtis Intelligent Computer Control System

Advanced Curtis electronic controller regulates or monitors all required forklift functions in all situations and settings to assure the AC motor's best efficiency and performance. The Curtis easy Self-Diagnostics and Intelligent Monitoring System (IMS) display indicators is thoroughly tested to assure the highest standard of reliability of the forklift during its operation.

Excellent Safety and Reliability

The N series is equipped with the wet disc brake which improves brake control greatly in all applications situations. Unlike conventional drum and shoe braking systems that require periodic checks and maintenance so the total cost of ownership is also reduced. Emergency power cut-off located at the right hand side near the control levers to ensure prompt emergency stop of the forklift under dangerous circumstance. Operator Presence Sensing System ensures that truck is operated only when the operator is seated to avoid incidents caused by unauthorized person. Parking Brake Warning ensures the parking brake is corrected applied whenever the operator leave the forklift. Operator restraint system with retractable seat belt for safe operation.



Easy Service and maintenance Access

The N series offer a gas-spring-assisted battery hood to make battery checks and maintenance easier to perform. Downtime is further reduced through the use of its Curtison-board self-diagnostic system that makes troubleshooting and repairs quick and simple. The controller is housed within a compartment designed to prevent the entry of dust, water and other possible contaminants, yet the cover can be removed for easy and quick service and maintenance.



Great comfort and ergonomic design for easy and comfortable operation

The N Series is designed with full consideration of the comfort and ergonomic of the operator to ensure the best efficiency and productivity is delivered with easy and comfortable operation. All lights are LED to ensure the best view in dark area operation. Small diameter steering wheel with spinner knob and on-demand Fully Hydrostatic Power Steering (FHPS) ensures effortless steering of the forklift during operation. Spacious step area with anti-slip design and a large hand grip for easy entry and exit. Comfort Package including Rear Grab Bar with horn + Left & Right Rearview Mirrors + USB Connector + Deluxe Grab Bar + Deluxe Full Suspension Seat operation to make the job easier.

Smart Open Side Battery Access Door

The N Series provides for several ways to easily remove or exchange the truck battery facilitating continuous multi-shift operations with its easy open side battery access door, so you can either replace the battery from side or hang from the top as most of the forklifts.



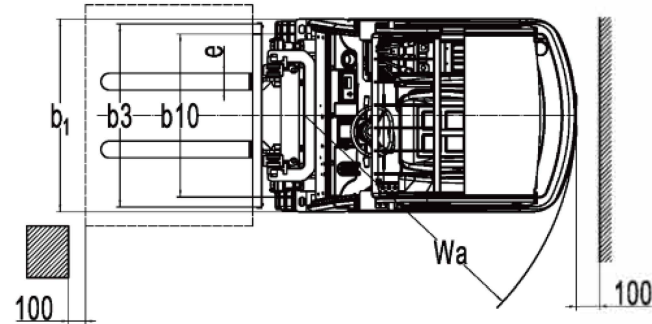
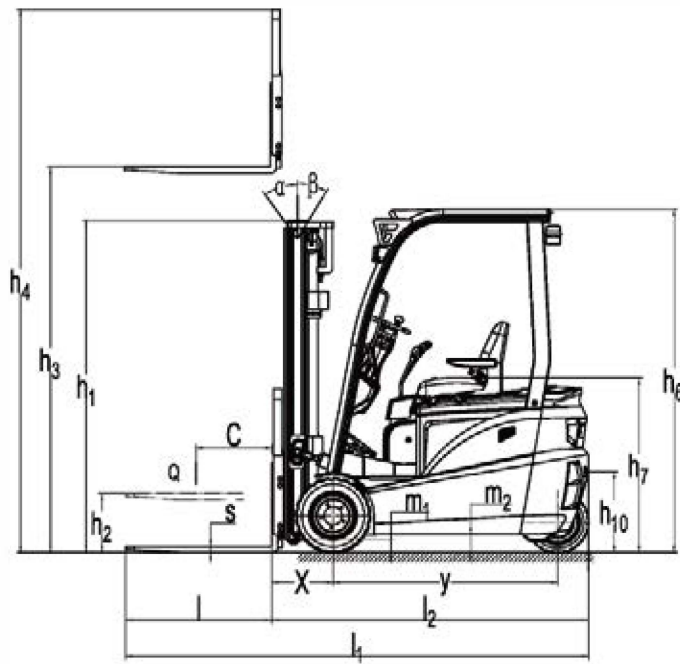

Mast Table FE3D16-20N

Designation	Lift height h3 (mm)	Free Lift h2 (mm)	Closed mast height h1 (mm)	Extended mast height h4 (mm)	Tilt forward/backward $\alpha / \beta (^{\circ})$	Capacity table(kg) C=500mm without sideshift, single solid tyres		
						FE3D16N	FE3D18N	FE3D20N
Two-stage ZT	2500	125	1758	3481	5/7	1600	1800	2000
	2700	125	1858	3681	5/7	1600	1800	2000
	3000	125	2008	3981	5/7	1600	1800	2000
	3300	125	2158	4281	5/7	1600	1800	2000
	3500	125	2258	4481	5/7	1600	1800	2000
	3700	125	2358	4681	5/7	1600	1800	2000
	4000	125	2558	4981	3/5	1500	1750	1900
	4300	125	2708	5281	3/5	1450	1650	1800
	4500	125	2808	5481	3/5	1400	1450	1600
5000	125	3083	5981	3/5	1000	1100	1400	
Two-stage ZZ	2500	793	1758	3474	5/7	1600	1800	2000
	2700	893	1858	3674	5/7	1600	1800	2000
	3000	1043	2008	3974	5/7	1600	1800	2000
	3300	1193	2158	4274	5/7	1600	1800	2000
	3500	1293	2258	4474	5/7	1600	1800	2000
	3700	1393	2358	4674	5/7	1600	1800	2000
	4000	1593	2558	4974	3/5	1500	1750	1900
	4300	1743	2708	5274	3/5	1450	1650	1800
	4500	1843	2808	5474	3/5	1400	1450	1600
5000	2118	3083	5974	3/5	1000	1100	1400	
Three-stage DZ	4000	988	1953	4980	3/5	1500	1750	1900
	4350	1113	2078	5329	3/5	1450	1600	1700
	4500	1163	2128	5479	3/5	1400	1450	1600
	4800	1263	2228	5779	3/5	1200	1300	1400
	5000	1363	2328	5979	3/5	1050	1100	1300
	5500	1513	2478	6479	3/5	800	900	1000
6000	1713	2678	6565	3/5	600	650	700	

Type sheet for industrial truck acc. to VDI 2198

1KG=2.2LB 1INCH=25.4MM

Identification		FE3D16N	FE3D18N	FE3D20N
1.2	Manufacturer's type designation	FE3D16N	FE3D18N	FE3D20N
1.3	Drive:electric(battery or mains),diesel,petrol gas,manual)	electric	electric	electric
1.4	Type of operation(hand,pedestrian,standing,seated,order-picker)	seated	seated	seated
1.5	Load capacity/rated load	Q(kg) 1600	1800	2000
1.6	Load centre distance	c(mm) 500	500	500
1.8	Load distance,centre of drive axle to fork	x(mm) 372	377	377
1.9	wheelbase	y(mm) 1360	1360	1490
Weights				
2.1	Service weight incl. battery	kg 3060	3160	3420
2.2	Axle loading ,laden front/rear	kg 4160/500	4450/510	4880/540
2.3	Axle loading,unladen front/rear	kg 1470/1610	1530/1650	1670/1750
Wheels - Chassis				
3.1	Type:solid rubber,superelectric,pneumatic,polyurethane	superelastic	superelastic	superelastic
3.2	Tyres size,front	18x7-8	18x7-8	200/50-10
3.3	Tyres size,rear	15X4½-8	15X4½-8	15X4½-8
3.5	Wheels,number front/rear(x=driven wheels)	2x/2	2x/2	2x/2
3.6	Track width,front	b10(mm) 960	960	984
3.7	Track width,rear	b11(mm) 180	180	180
Basic Dimensions				
4.1	Mast/fork carriage tilt forward/backward	$\alpha / \beta (^{\circ})$ 5/7	5/7	5/7
4.2	lowered mast height	h1(mm) 2008	2008	2008
4.3	Free lift	h2(mm) 125	125	125
4.4	Lift height	h3(mm) 3000	3000	3000
4.5	Extended mast height	h4(mm) 3981	3981	3981
4.7	Overhead load guardheight	h6(mm) 2075	2075	2075
4.8	Seat height/standing height	h7(mm) 1030	1030	1030
4.12	Coupling height	h10(mm) 465	465	465
4.19	Overall length	l1(mm) 2845	3000	3130
4.20	Length to face of forks	l2(mm) 1925	1930	2060
4.21	Overall width	b1(mm) 1135	1135	1135
4.22	Fork dimensions	s/e/l(mm) 35/100/920	40/100/1070	40/120/1070
4.24	Fork carriage width	b3(mm) 1040	1040	1040
4.31	Ground clearance ,laden,under mast	m1(mm) 123	123	123
4.32	Ground clearance,centre of wheelbase	m2(mm) 105	105	105
4.33	Aisle width for pallets 1000x1200 crossways	Ast(mm) 3248	3253	3383
4.34	Aisle width for pallets 800x1200 lengthways	Ast(mm) 3373	3377	3507
4.35	Turning radius	Wa(mm) 1550	1550	1680
Performance Data				
5.1	Travel speed,laden/unladen	km/h 14/15	14/15	14/15
5.2	Lift speed,laden/unladen	m/s 0.32/0.42	0.32/0.42	0.32/0.42
5.3	lowering speed,laden/unladen	m/s <0.6	<0.6	<0.6
5.5	Drawbar pull,laden/unladen S2 60 min	N 13000	14000	16000
5.7	Max.Gradient performance,laden/unladen S2 5 min	% 15/20	15/20	13/18
5.10	Service brake	hydraulic	hydraulic	hydraulic
E-Motor				
6.1	Drive motor rating S2 60 min	kW 4.5x2	4.5x2	4.5x2
6.2	Lift motor rating at S3 15%	kW 8.6	8.6	8.6
6.3	Battery standard	BS	BS	BS
6.4	Battery voltage,nominal capacity K5	V/Ah 48/455 (48/490 48/560)	48/455 (48/490 48/560)	48/560 (48/630)
6.4	Battery weight	kg 800	800	950
6.4	Battery dimensions l/w/h	mm 980x538x670	980x538x670	980x668x670
Other Details				
8.1	Type of drive control	AC	AC	AC
8.2	Operating pressure for attachments	Mpa 17.5	17.5	17.5
8.3	Oil volume for attachments	l/min 36	36	36
8.4	Sound level at driver's ear according to EN 12 053	dB(A) 70	70	70